

MOD. PC3000-OC2, PC4000ML, PC4000-OC1 & PC4000-OC2 PROFESSIONAL TACKERS

CAUTION: Read instructions carefully before operating Tacker, and save them for future reference.

* THE ABOVE TOOLS ARE NON-SERVICEABLE FOR U.S. RESIDENTS ONLY, EXCEPT PART NO. 103887, 103885 & 103886

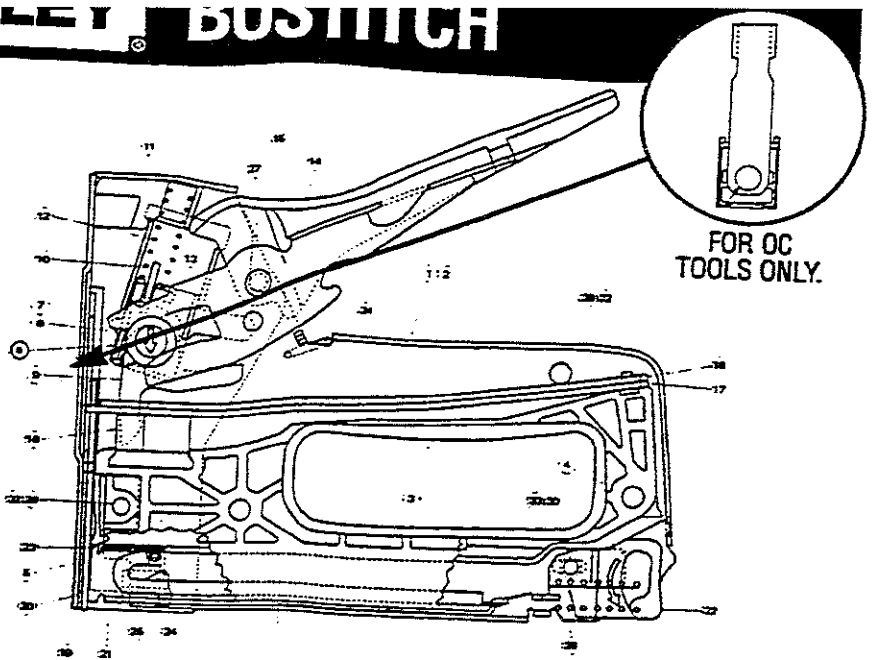

* = NON-SERVICEABLE FRAME ASSEMBLY

ITEM	PART NO.	DESCRIPTION	QTY.	ITEM	PART NO.	DESCRIPTION	QTY.
1	107261	LEFT FRAME*	1	20	103706	CHANNEL, STCR, O.C., PC3000-OC2, PC4000ML & PC4000-OC1 & PC4000-OC2	1
2	107262	RIGHT FRAME*	1	21	101286	CORE PC4000ML	1
3	105408	GUIDE BODY*	1	21	103955	ASSY., CORE, O.C. 2619	1
4	101313	RIVET*	2	21	103954	ASSY., CORE, O.C. 5019	1
5	106054	NOSE PC4000ML	1	22	101331	CORE LATCH	1
5	106055	NOSE, O.C., POWERCROWN, PC3000-OC2, PC4000-OC1 & PC4000-OC2	1	23	104947	PUSHER	1
6	105826	LIFT BEARING	1	24	B626007	PUSHER SPRING	1
7	105827	LEFT SLIDE	1	25	101288	SPRING ROLL	1
8	105828	RIGHT SLIDE	1	26	101335	CORE SPRING	1
9	107175	LIFT PAWL	2	27	101336	HANDLE PIVOT	1
10	103411	SPRING SEAT	1	28	101337	NOSE PIN	1
11	101320	HANDLE BUMPER	1	29	102390	SPRING PIN	1
12	101321	RETURN SPRING	2	30	101339	CORE LATCH PIN	1
13	101322	PAWL PIN	2	31		NONE	
14	101323	OPERATING LEVER	1	32	85018	E-RING	2
15	101324	HANDLE	1	33	101342	E-RING	1
16	104450	TOP SPRING	1	34	101279	HANDLE LOCK	1
17	104451	BOTTOM SPRING	1	35		NONE	
18	101327	SPRING BUMPER	1	36	104132	NOSE LABEL, PC3000-OC2	1
19	101284	DRIVER PC4000ML & OC's	1	36	104188	NOSE LABEL, PC4000ML	1
19	101305	DRIVER PC3000-OC2	1	36	104133	NOSE LABEL, PC4000-OC1	1
20	101285	CHANNEL	1	36	104134	NOSE LABEL, PC4000-OC2	1
				37	103887	ASSY. PLATE, 2619, OC2	1
				37	103885	ASSY., PLATE, 5019, OC1	1
				37	103886	ASSY., PLATE, 5019, OC2	1

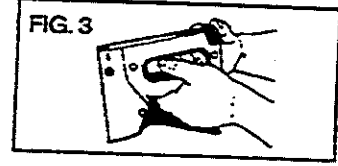
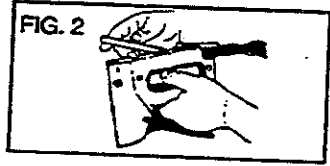
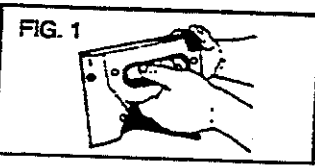

LOADING: 1) Hold Tacker upside down as shown in Fig. 1 and release loading latch. Pull slide open. 2) Place stick of staples in bottom channel as shown in Fig. 2 so legs are pointing up. 3) Push slide closed as shown in Fig. 3, making sure that latch engages.

STAPLES REQUIRED:

STCR2619	1/4" 6mm	3/8" 10mm	1/2" 12mm
PC3000-OC2			✓

STCR5019	1/4" 6mm	3/8" 10mm	1/2" 12mm	9/16" 14mm
PC4000 & ML				